

WINCH MOD. W 16.2 ST

Black anodized aluminium & chromed bronze

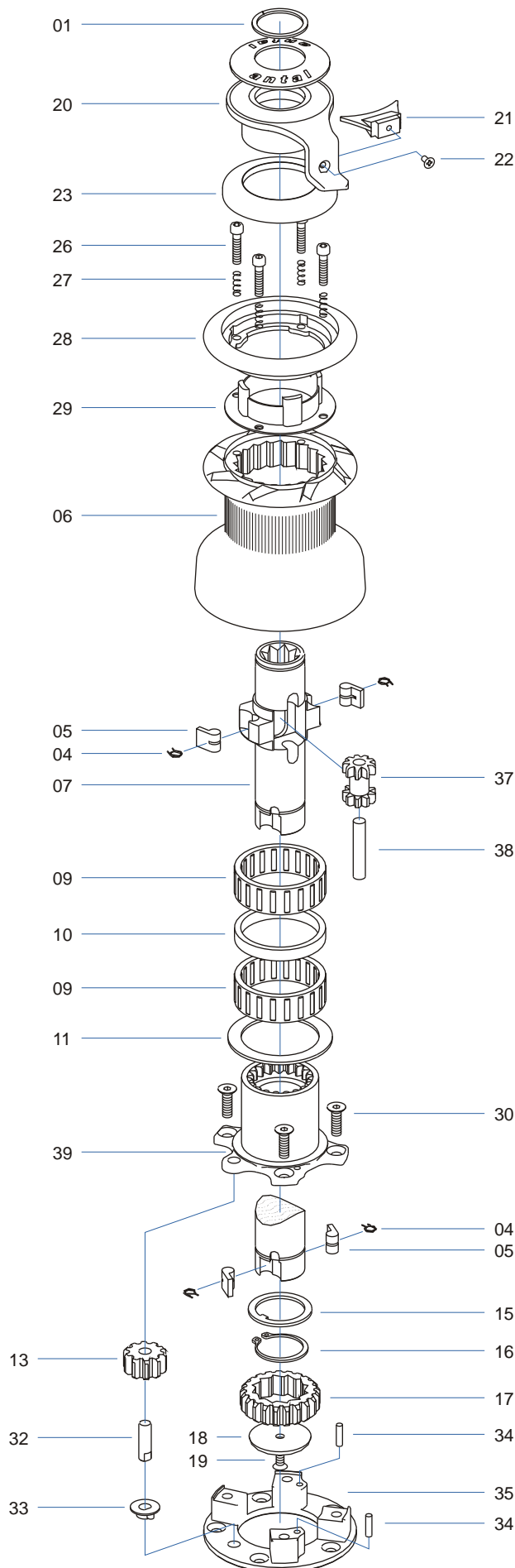

PARTS LIST 04/2001

KEY N.	DESCRIPTION	QUANT.
01	CIRCLIP	1
02	S.STEEL CAP	1
04	PAWL SPRING	4
05	PAWL	4
06	DRUM	1
07	S.STEEL SHAFT	1
09	BASE ROLLER BEARING	2
10	PLASTIC SPACER	1
11	PLASTIC WASHER	1
13	BRONZE GEAR "B1"	1
15	S.STEEL WASHER	1
16	SEGER	1
17	BRONZE GEAR "A1"	1
18	PLASTIC CAP	1
19	SCREW	1
20	ST ARM	1
21	STRIPPER	1
22	SCREW	1
23	PLASTIC CAP	1
26	SCREW	4
27	ST SPRING	4
28	UPPER ST DISK	1
29	PLASTIC WASHER	1
30	SCREW	4
32	S.STEEL SPINDLE	1
33	PLASTIC WASHER	1
34	S.STEEL PIN	2
35	ALU LOWER BASE	1
37	BRONZE GEAR "C1"	1
38	S.STEEL SPINDLE	1
39	CHROMED BRONZE BASE	1

WINCH MOD. W 16.2 ST

Black anodized aluminium & chromed bronze

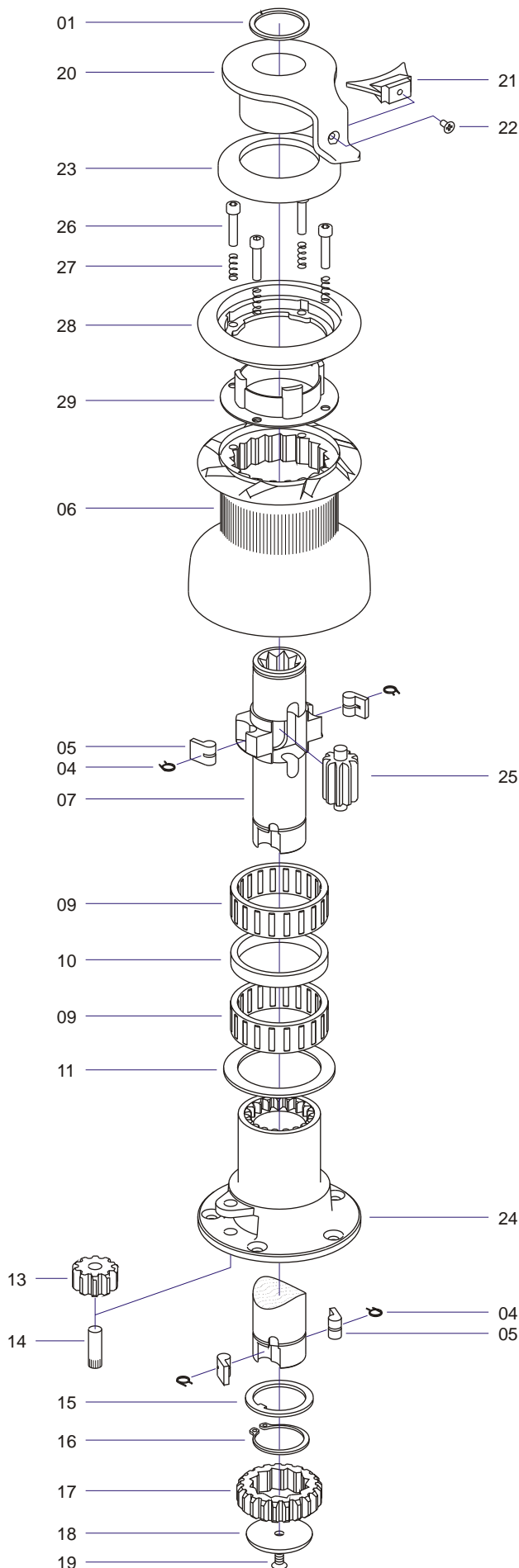

PARTS LIST 09/99

KEY N.	DESCRIPTION	QUANT.
01	CIRCLIP	1
04	PAWL SPRING	4
05	PAWL	4
06	DRUM	1
07	S.STEEL SHAFT	1
09	BASE ROLLER BEARING	2
10	PLASTIC SPACER	1
11	PLASTIC WASHER	1
13	BRONZE GEAR "B1"	1
14	S.STEEL SPINDLE	1
15	S.STEEL WASHER	1
16	SEGER	1
17	BRONZE GEAR "A1"	1
18	PLASTIC CAP	1
19	SCREW	1
20	ST ARM	1
21	STRIPPER	1
22	SCREW	1
23	PLASTIC CAP	1
24	BASE	1
25	BRONZE GEAR "C1"	1
26	SCREW	4
27	ST SPRING	4
28	UPPER ST DISK	1
29	PLASTIC WASHER	1

WINCH MOD. W 16.2 ST

Black anodized aluminium & chromed bronze

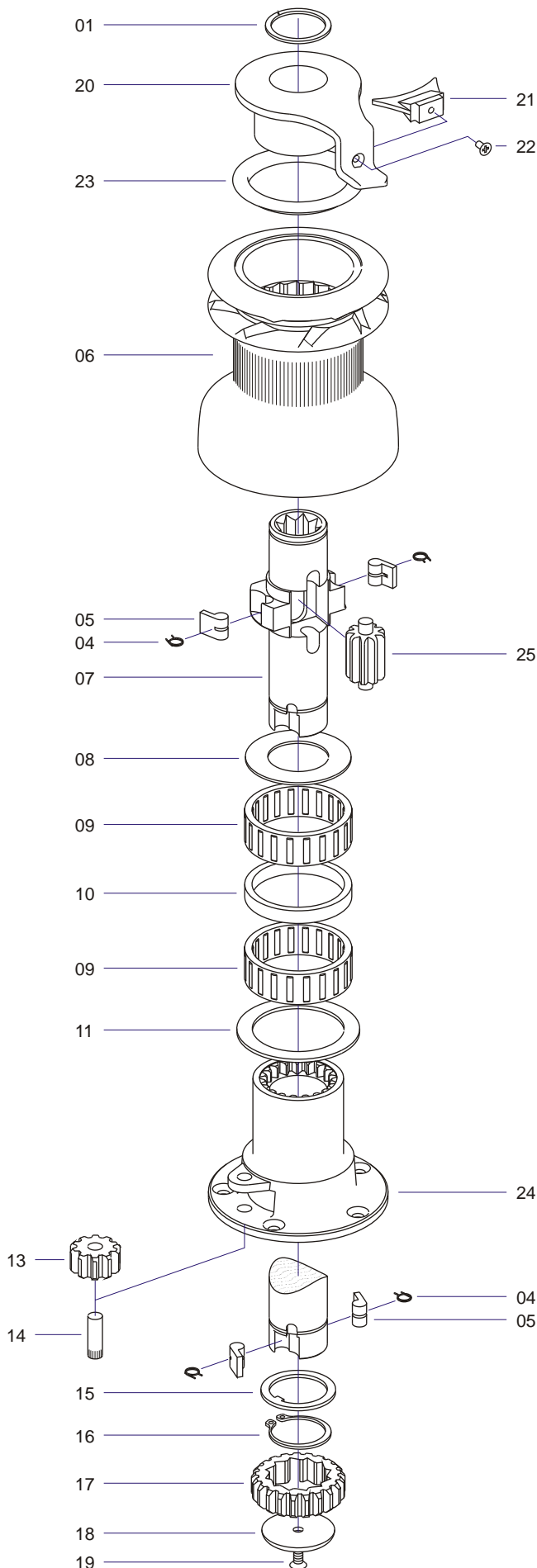

PARTS LIST 01/98

KEY N.	DESCRIPTION	QUANT.
01	CIRCLIP	1
04	PAWL SPRING	4
05	PAWL	4
06	DRUM	1
07	S.STEEL SHAFT	1
08	PLASTIC WASHER	1
09	BASE ROLLER BEARING	2
10	PLASTIC SPACER	1
11	PLASTIC WASHER	1
13	BRONZE GEAR "B1"	1
14	S.STEEL SPINDLE	1
15	S.STEEL WASHER	1
16	SEGER	1
17	BRONZE GEAR "A1"	1
18	PLASTIC CAP	1
19	SCREW	1
20	ST ARM	1
21	STRIPPER	1
22	SCREW	1
23	PLASTIC CAP	1
24	BASE	1
25	BRONZE GEAR "C1"	1