

WINCH MOD. W 30 ST

Black anodized aluminium & chromed bronze

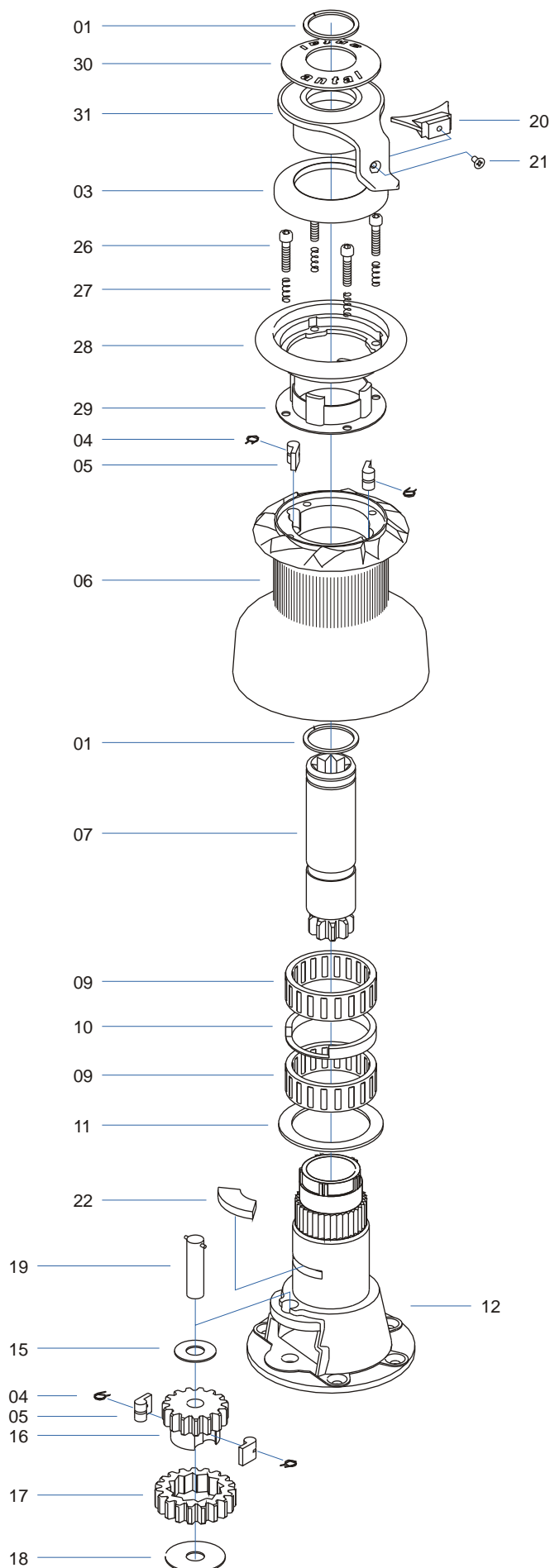

PARTS LIST 04/2001

KEY N.	DESCRIPTION	QUANT.
01	CIRCLIP	2
03	PLASTIC CAP	1
04	PAWL SPRING	4
05	PAWL	4
06	DRUM	1
07	S.STEEL SHAFT	1
09	BASE ROLLER BEARING	2
10	PLASTIC SPACER	1
11	PLASTIC WASHER	1
12	BASE	1
15	PLASTIC WASHER	1
16	BRONZE GEAR "B2"	1
17	BRONZE GEAR "B1"	1
18	PLASTIC WASHER	1
19	S.STEEL SPINDLE	1
20	STRIPPER	1
21	SCREW	1
22	PLASTIC SECTOR	1
26	SCREW	4
27	ST SPRING	4
28	UPPER ST DISK	1
29	PLASTIC WASHER	1
30	S.STEEL CAP	1
31	ST ARM	1

WINCH MOD. W 30 ST

Black anodized aluminium & chromed bronze

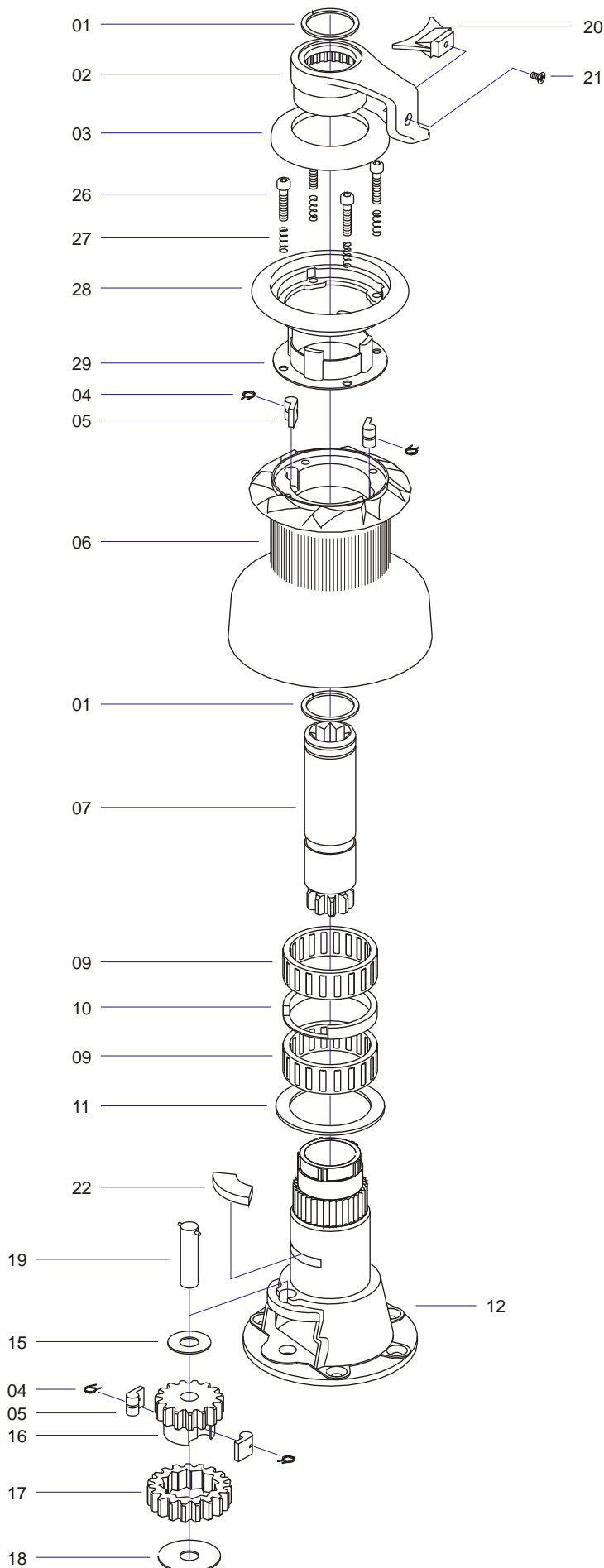

PARTS LIST 01/99

KEY N.	DESCRIPTION	QUANT.
01	CIRCLIP	2
02	ST ARM	1
03	PLASTIC CAP	1
04	PAWL SPRING	4
05	PAWL	4
06	DRUM	1
07	S.STEEL SHAFT	1
09	BASE ROLLER BEARING	2
10	PLASTIC SPACER	1
11	PLASTIC WASHER	1
12	BASE	1
15	PLASTIC WASHER	1
16	BRONZE GEAR "B2"	1
17	BRONZE GEAR "B1"	1
18	PLASTIC WASHER	1
19	S.STEEL SPINDLE	1
20	STRIPPER	1
21	SCREW	1
22	PLASTIC SECTOR	1
26	SCREW	4
27	ST SPRING	4
28	UPPER ST DISK	1
29	PLASTIC WASHER	1

WINCH MOD. W 28 ST

Black anodized aluminium & chromed bronze

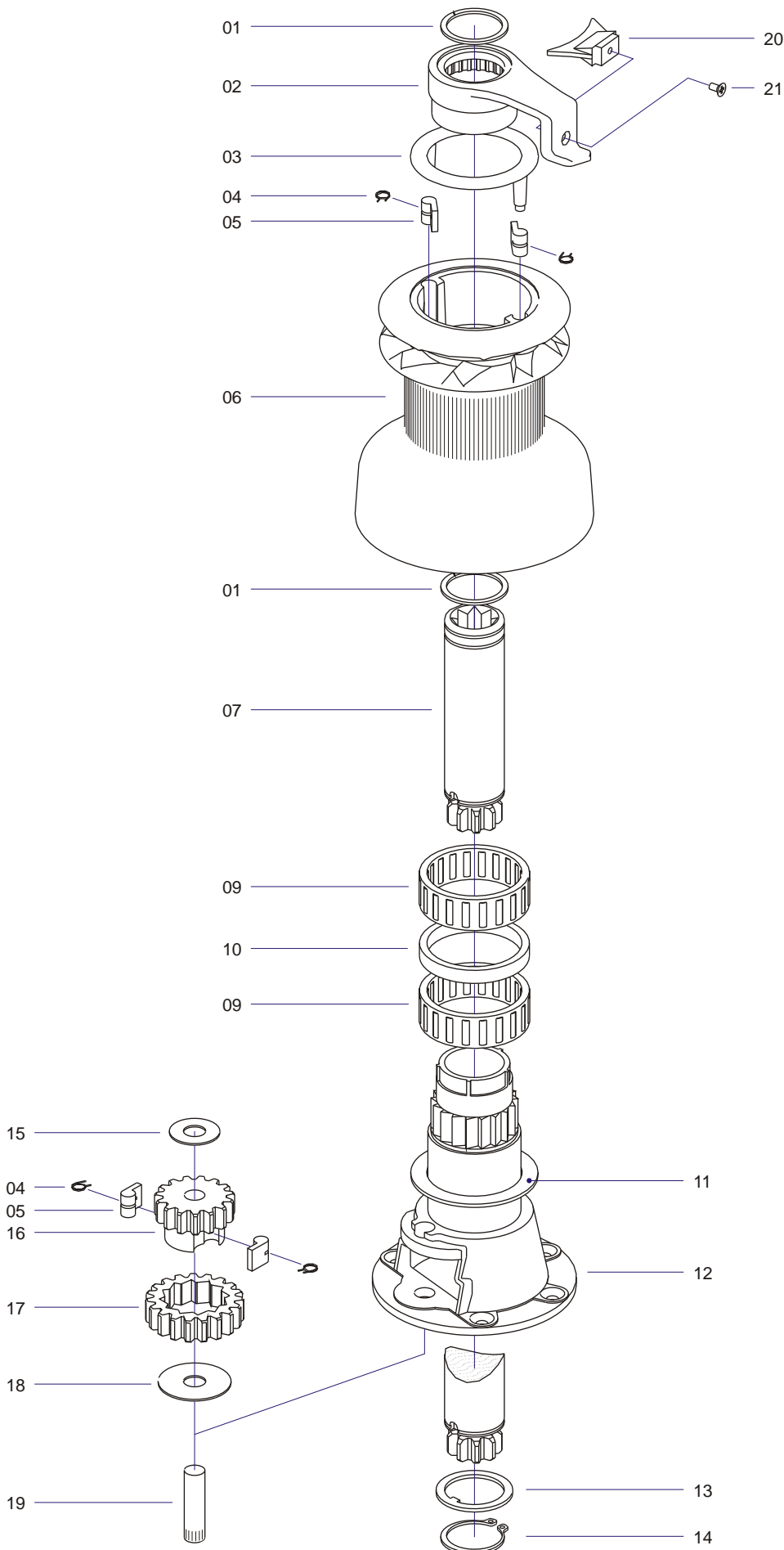

PARTS LIST 01/98

KEY N.	DESCRIPTION	QUANT.
01	CIRCLIP	2
02	ST ARM	1
03	PLASTIC CAP	1
04	PAWL SPRING	4
05	PAWL	4
06	DRUM	1
07	S.STEEL SHAFT	1
09	BASE ROLLER BEARING	2
10	PLASTIC SPACER	1
11	PLASTIC WASHER	1
12	BASE	1
13	S.STEEL SPINDLE	1
14	SEGER	1
15	PLASTIC WASHER	1
16	BRONZE GEAR "B2"	1
17	BRONZE GEAR "B1"	1
18	PLASTIC WASHER	1
19	S.STEEL SPINDLE	1
20	STRIPPER	1
21	SCREW	1